

HIGH POWER APC LASER DIODE DRIVER

FEATURES

- Automatic Power Control CW operation driving current up to 350mA
- Wide supply voltage from 2.1 to 6VDC, provided $(VDD-V(LD)) \times I(LDA) < 0.4W$
- APC TTL modulation frequency up to 20KHz, with adjustable duty cycle
- Rapid soft start after power-on
- Simple power adjustment via the external resistor
- Control loop accuracy up to 1% with changes in temperature
- Permanent shutdown with excessive temperature and pre-set current limit
- Wide monitor current range from 10 μ A to 0.5mA
- Worldwide laser safety regulations compliant, including TUV, JQA, CE and FDA
- Variable package type available, including Known Good Die, SOT26 and SOP8
- Support N type laser diode package

APPLICATIONS

- Laser Leveling
- Bar Code Reader
- Laser Measuring Equipment
- Laser Medical Equipment
- Diode Pumping Laser Driver

BLOCK DIAGRAM

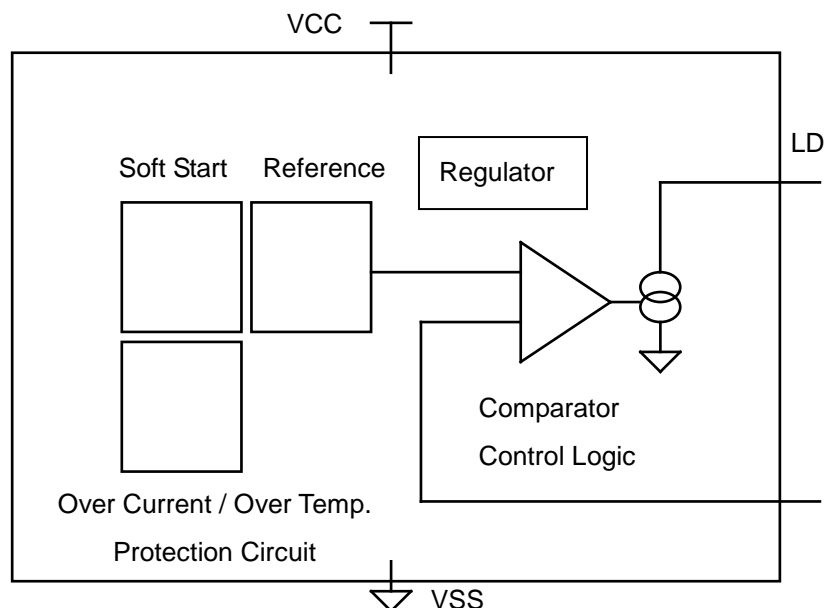

PIN CONFIGURATION (For EDL2M-SOP8, pin name applicable to KGD and SOT26)

| <i>No.</i> | <i>Name</i> | <i>Function</i> |
|------------|-------------|------------------------------|
| 1 | MDA | Photo Diode (PD or MD) Anode |
| 2 | GND | Ground |
| 3 | SS | Soft Start Ramping Control |
| 4 | LDA | Driver Output (LD Anode) |
| 5 | VDD | +2.1~ 6V Supply Voltage |
| 6 | PRO | Max Driving Current Control |
| 7 | OSC | Built-in Oscillation Output |
| 8 | EN | Enable or TTL signal Input |

PIN CONFIGURATION (For EDL2J-SOT26)

| <i>No.</i> | <i>Name</i> | <i>Function</i> |
|------------|-------------|--|
| 1 | PRO | Max Driving Current Control for Protecting |
| 2 | VDD | +2.1-6V Supply Voltage |
| 3 | SS | Soft Start Ramping Control |
| 4 | LDA | Driver Output (LD Anode) |
| 5 | GND | Ground |
| 6 | MDA | Photo Diode (PD or MD) Anode |

APPLICATION CONNECTION

- KGD Pinout
- SOT26
- SOP8

We Treasure Innovation!

EDL2-DIE

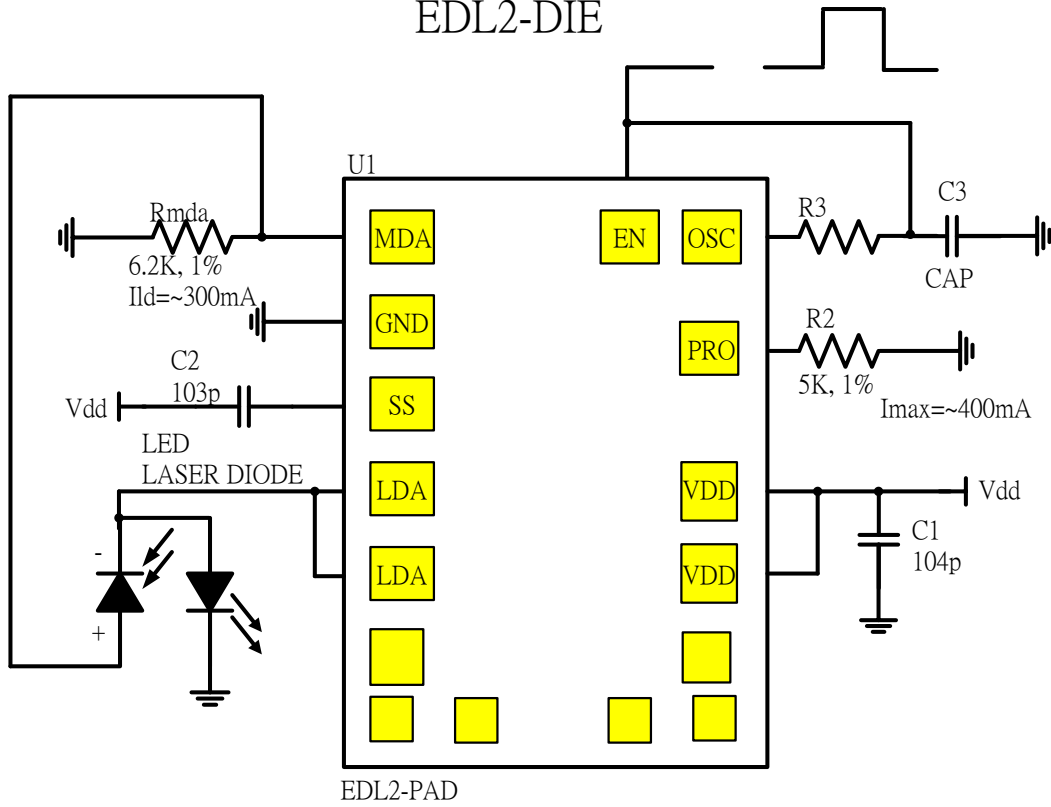

EDL2J-SOT26

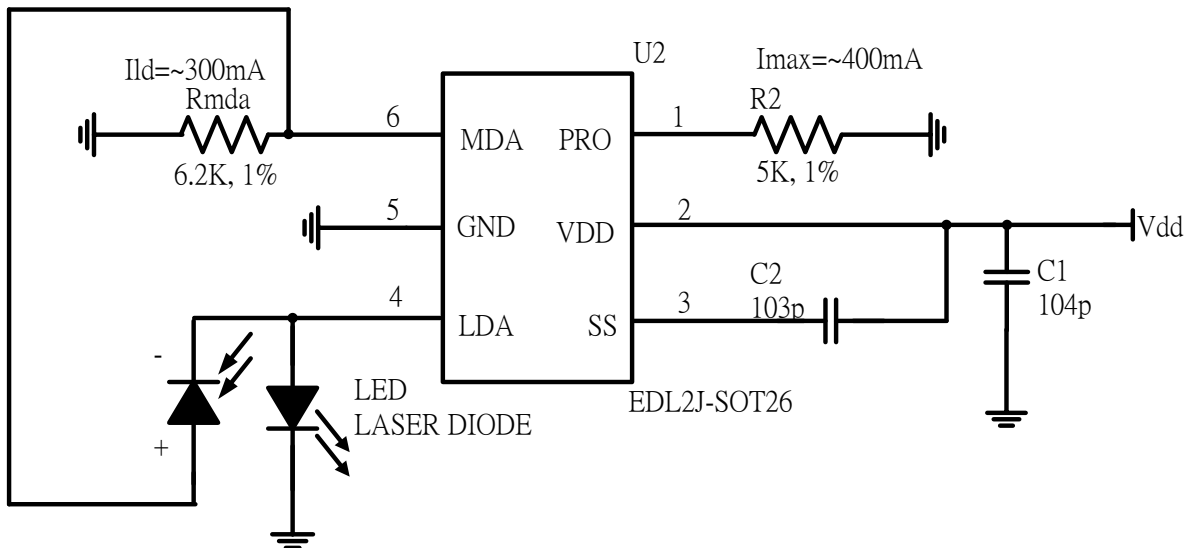

EDL2M-SOP8

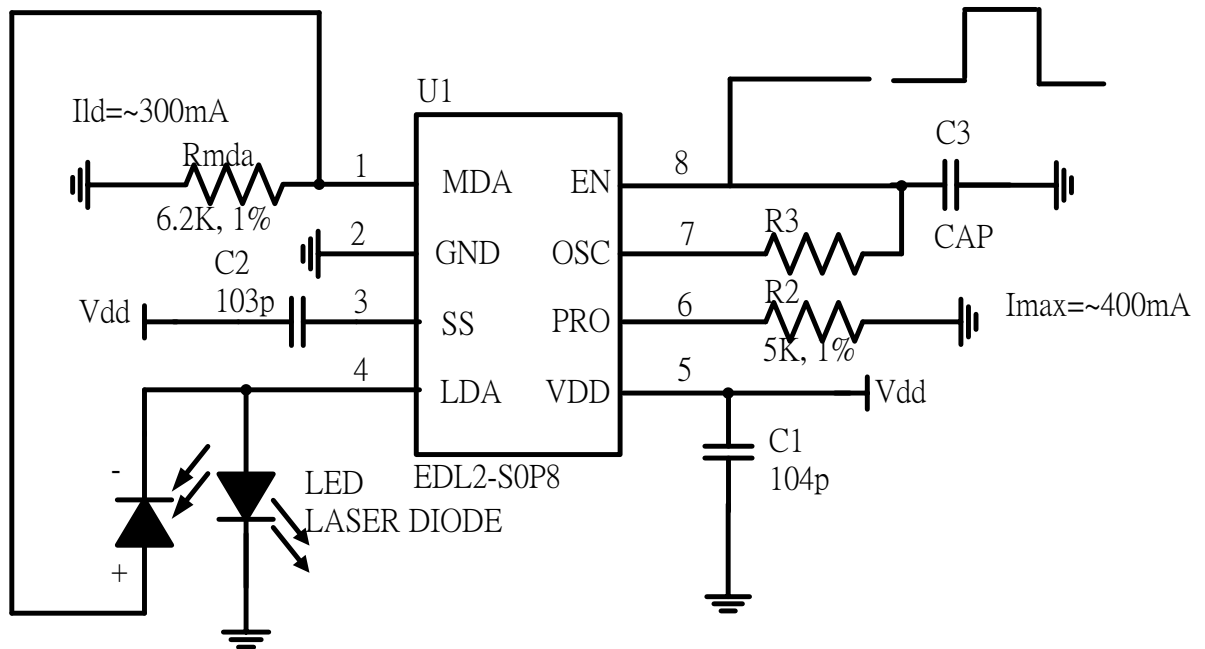

DESCRIPTION

The EDL2 High Power APC Laser Diode Driver device is a driver and controller for laser diodes in both continuous wave and up to 20KHz TTL modulation operation which requires only few external components. The broad power supply range of 2.1V to 6V and the integrated reverse battery protection allow for battery operation with a minimum of two cells.

The driver includes integrated circuitry protecting against destruction by ESD, excessive temperature and over current and a soft start which regulates the power and protects the laser diode when the power supply is switched on. The driver also filters the laser diode power supply for transients.

The power supply is regulated and adapted for the laser diode used by an external resistor at PD. The monitor current acts as a reference and is regulated independent of the influence of temperature and supply voltage (range: 10µA to 0.5mA). It is designed to meet the stringent worldwide laser safety regulation, TUV, JQA, CE and FDA etc, requirement and the harsh industrial operation environment.

In the event of failure, such as over current in the laser path with a lack of feedback, for example, a quick power lockout is activated. The shutdown continues until power is

reapplied, permitting a restart. The strain on power packs and batteries is relieved and the laser class is retained even in the event of a disturbance.

Given the tiny package size, the maximum allowable power dissipation over EDL2 is recommended to be less than 0.4W. For example, if V_{op} of a given laser diode is 2.5VDC, the allowable I_{op} and VDD combination can be 6VDC, with I_{op} of laser diode less than 110mA; or 3VDC, with I_{op} less than 350mA. The rule of thumb is $(VDD - V_{op}) \times I_{op} \leq 0.4W$.

ABSOLUTE MAXIMUM RATINGS

Beyond these values damage may occur; device operation is not guaranteed.

| Symbol | Parameter | Conditions | Min. | Typ. | Max. | Unit |
|------------|--------------------------------|--|------|------|------|------|
| VDD | Voltage at VDD | | -0.5 | | 7 | V |
| I(VCC) | Current in VDD | | -100 | | 600 | mA |
| I(LDA) | Current in LD | | | | 500 | mA |
| I(MDA) | Current in PD | | | | 6 | mA |
| VR | Reverse Voltage | | | | -4 | V |
| VD | ESD Susceptibility at all pins | MIL-STD-883, Method 3015, HBM 100pF discharged through 1.5kS | | | 1 | kV |
| Tsoldering | Soldering Temperature | 260°C for 10 seconds (SOIC)* | | | | |
| Tj | Operating Junction Temperature | | -40 | | 150 | °C |
| Ts | Storage Temperature Range | | -55 | | 125 | °C |

*See IPC/JEDEC Standard J-STD-020A for Surface Mount Devices.

THERMAL DATA

Operating Conditions: VDD= 2.1..6V

| Symbol | Parameter | Conditions | Min. | Typ. | Max. | Unit |
|--------|-------------------------------------|---|------|------|------|------|
| Ta | Operating Ambient Temperature Range | | -20 | | 80 | °C |
| Rthja | Thermal Resistance Chip / Ambient | SOT26 package, soldered on PCB, no additional cooling areas | | | 140 | K/W |

All voltages are referenced to ground unless otherwise noted.

All currents into the device pins are positive; all currents out of the device pins are negative.

ELECTRICAL CHARACTERISTICS

Operating Conditions: VDD= 5V, VR= 2KΩ..100KΩ, Ta= 0-70°C unless otherwise noted

| Symbol | Parameter | Conditions | Min. | Typ. | Max. | Unit |
|--------|---|--|------|------|------|------|
| VDD | Permissible Supply Voltage | $(VDD-Vop) \times Iop \leq 0.4 \text{ W}$ | 2.1 | | 6 | V |
| I(LDA) | Permissible Laser Diode Current | power control range $(VDD-Vop) \times Iop \leq 0.4 \text{ W}$ | 5 | | 350 | mA |
| I(MDA) | Permissible Photo Diode Current | IMDA drive current = VMDA/RMDA | 10 | | 500 | μA |
| V(MDA) | Photo diode monitor Voltage | power control range | | 1.2 | | V |
| V(PRO) | Laser Diode Protection Monitor Voltage | LDA output protect current = $(VPRO \times 1600 / RPRO)$ | | 1.2 | | V |
| Tss | Soft start turn on delay | @Css=1nF | | 30 | | us |
| R(PRO) | Max Driving Current Adjustment Resistor | I(LDA) from 78mA to 360mA | 3.9 | | 27 | KΩ |

LASER MODULE LAYOUT EXAMPLE

Reference schematic design:

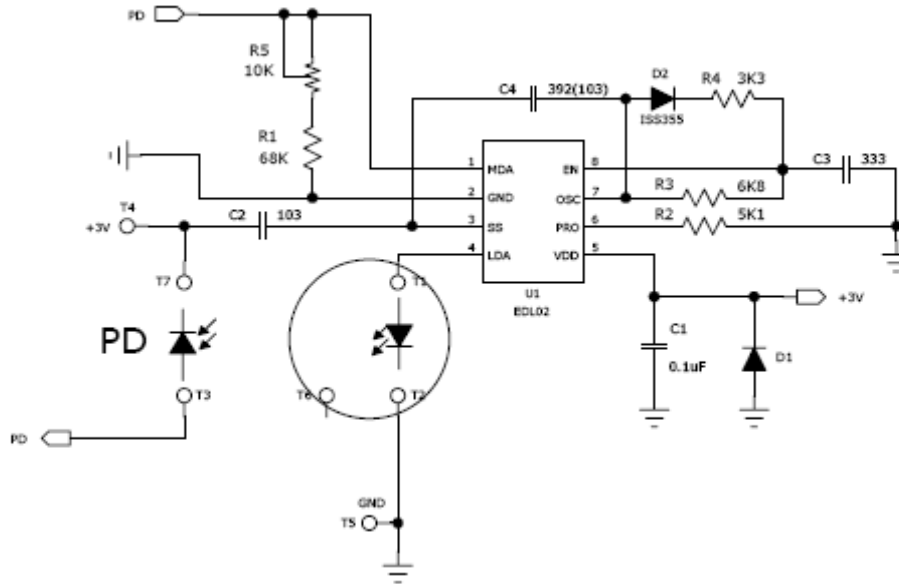

Reference for over current protection

| Laser Diodes NO.1 characteristics | | |
|-----------------------------------|------------------------------|---------------|
| Resistance (KΩ) | Maximum current allowed (mA) | Diode voltage |
| 2 | 425 | 1.38 |
| 3 | 415 | 1.37 |
| 4 | 420 | 1.38 |
| 5 | 390 | 1.33 |
| 6 | 310 | 1.23 |
| 7 | 255 | 1.17 |
| 8 | 215 | 1.13 |
| 10 | 165 | 1.08 |
| 12 | 135 | 1.03 |
| 14 | 115 | 1.01 |
| 16 | 100 | 1 |
| 18 | 90 | 0.97 |
| 20 | 75 | 0.95 |

| Laser Diodes NO.2 characteristics | | |
|-----------------------------------|------------------------------|---------------|
| Resistance (KΩ) | Maximum current allowed (mA) | Diode voltage |
| 2 | 520 | 2.53 |
| 3 | 490 | 2.39 |
| 4 | 380 | 2.2 |
| 5 | 305 | 2.11 |
| 6 | 255 | 2.06 |
| 7 | 215 | 2.01 |
| 8 | 185 | 1.95 |
| 10 | 145 | 1.92 |
| 12 | 120 | 1.86 |
| 14 | 100 | 1.84 |
| 16 | 90 | 1.83 |
| 18 | 75 | 1.79 |
| 20 | 65 | 1.76 |

| Laser Diodes NO.3 characteristics | | |
|-----------------------------------|------------------------------|---------------|
| Resistance (KΩ) | Maximum current allowed (mA) | Diode voltage |
| 2 | 600 | 3.72 |
| 3 | 450 | 3.25 |
| 4 | 350 | 3.07 |
| 5 | 285 | 3 |
| 6 | 240 | 2.94 |
| 7 | 205 | 2.88 |
| 8 | 175 | 2.81 |
| 10 | 140 | 2.8 |
| 12 | 115 | 2.73 |
| 14 | 100 | 2.72 |
| 16 | 90 | 2.69 |
| 18 | 80 | 2.67 |
| 20 | 70 | 2.63 |

Voltage and current of a laser diode can be inferred from different external resistance above.

We Treasure Innovation!

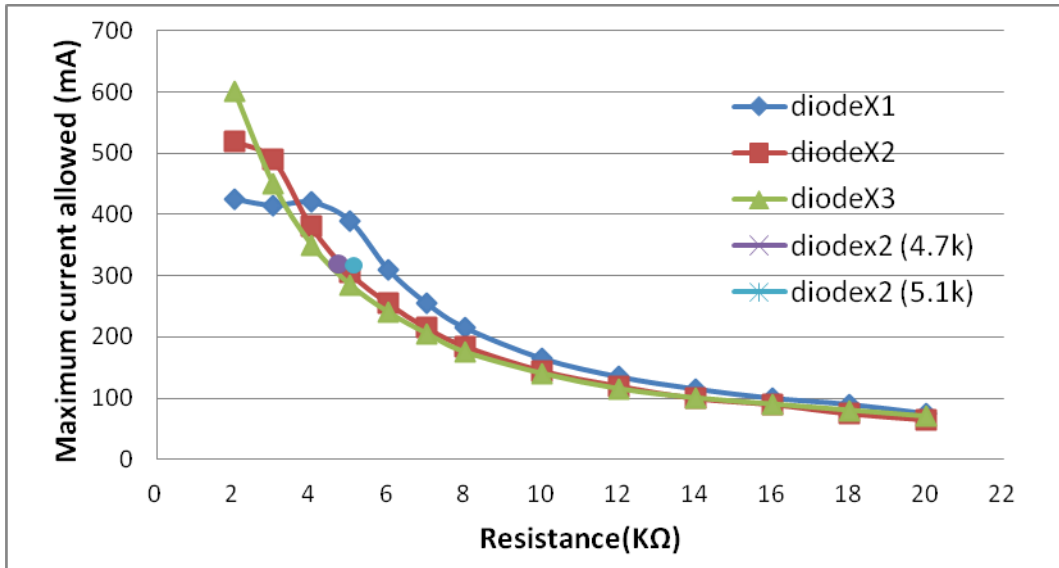

1. Laser output power adjustment: RS
2. Max laser diode driving current limit: R2
3. TTL modulation frequency adjustment: R3, C3
4. TTL modulation duty cycle adjustment: R4, D2
5. Soft start turn-on delay control: C2

Reference layout design (for two layers PCB):

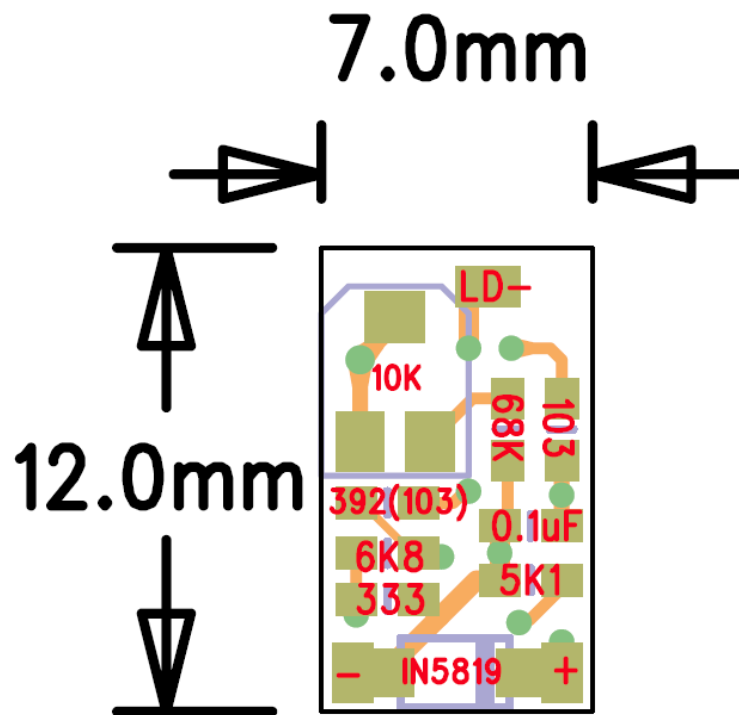
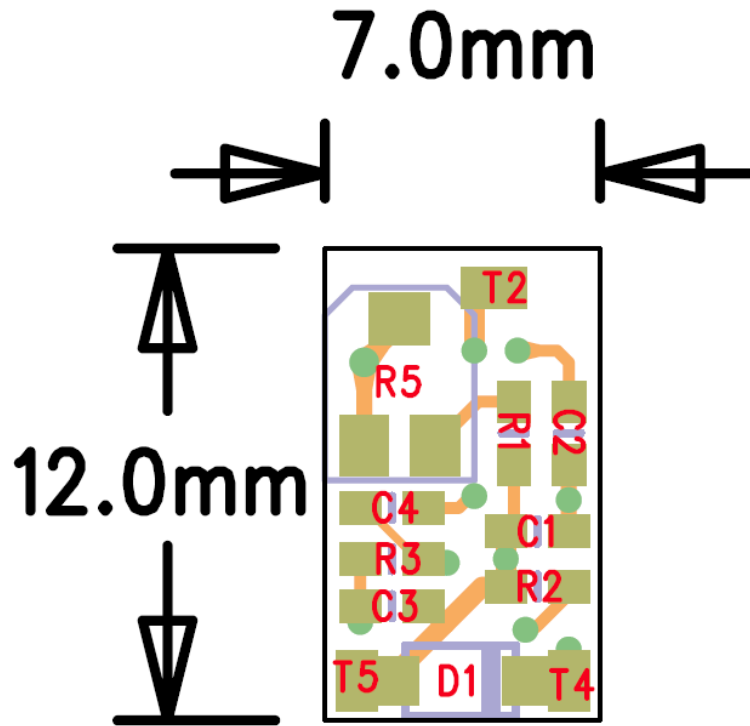

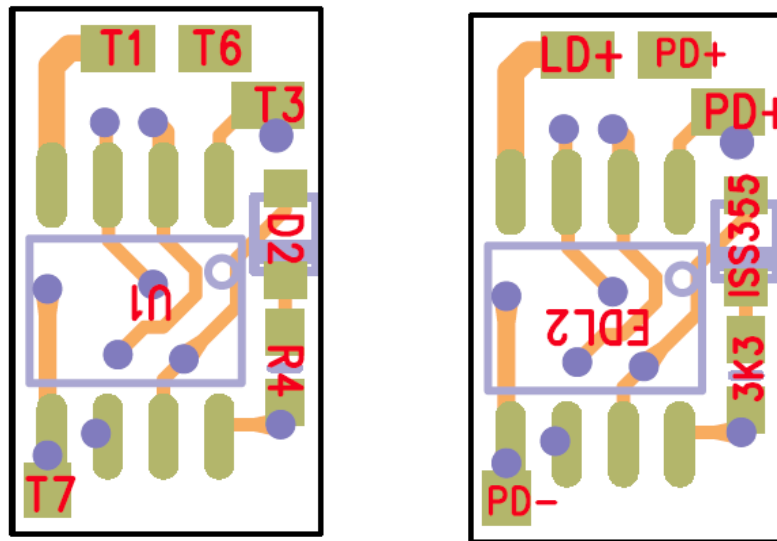

Demo board operation procedure:

1. Adjust RS to max value, 20K ohm is recommended <- **VERY IMPORTANT!**
2. Decide the best Vop and Iop of laser diode combination by referring to allowable power consumption equation $(VDD - Vop) \times Iop \leq 0.5W$
3. Set max. driving current limit for overcurrent protection by adjusting R2
4. Set soft start delay time by adjusting C2
5. For continuous wave operation, set EN High and leave OSC open, go directly to the final step
6. For TTL modulation operation, adjusting R3, C3 for desired modulation frequency
7. For TTL modulation operation, adjusting D2, R4 for desired duty cycle ratio. Forward biased D2, as shown in schematic, leads to extended High ratio; Reversed biased D2 leads to extended Low ratio
8. The value of C4 affects both soft start delay time Tss and max. TTL modulation frequency. In order to stabilize LDA output current, C2 + C4 should be in between 500pf~1500pF. The ratio of C4/C2 depends on target LDA current, for higher LDA current, higher C4/C2 ratio is suggested.
9. For external TTL modulation signal input, remove R3, C4, R4, C4 and D2 so QSC is floating, and connect TTL signal, square wave, directly to EN
10. EN pin is Schmitt trigger input with $V_{ih} \sim 1.45V$, $V_{il} \sim 0.95V$ @ Vdd=3V
11. Adjusting RS to obtain desired laser power output

SOT26 Package Drawing

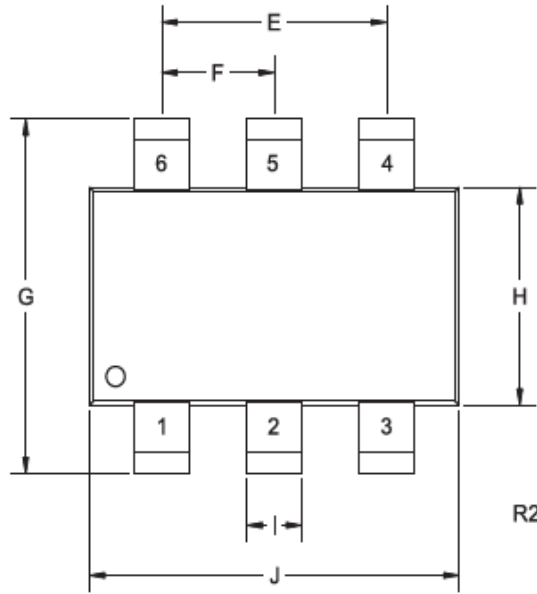
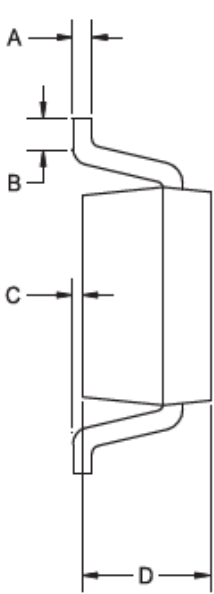

| SYMBOL | DIMENSIONS | | | |
|--------|------------|-------|-------------|------|
| | INCHES | | MILLIMETERS | |
| | MIN | MAX | MIN | MAX |
| A | 0.004 | 0.007 | 0.11 | 0.19 |
| B | 0.016 | - | 0.40 | - |
| C | - | 0.004 | - | 0.10 |
| D | 0.039 | 0.047 | 1.00 | 1.20 |
| E | 0.074 | 0.075 | 1.88 | 1.92 |
| F | 0.037 | 0.038 | 0.93 | 0.97 |
| G | 0.102 | 0.118 | 2.60 | 3.00 |
| H | 0.059 | 0.067 | 1.50 | 1.70 |
| I | 0.016 | | 0.41 | |
| J | 0.110 | 0.118 | 2.80 | 3.00 |

SOT-26 (REV: R2)

Lead Code:
Reference individual device datasheet.

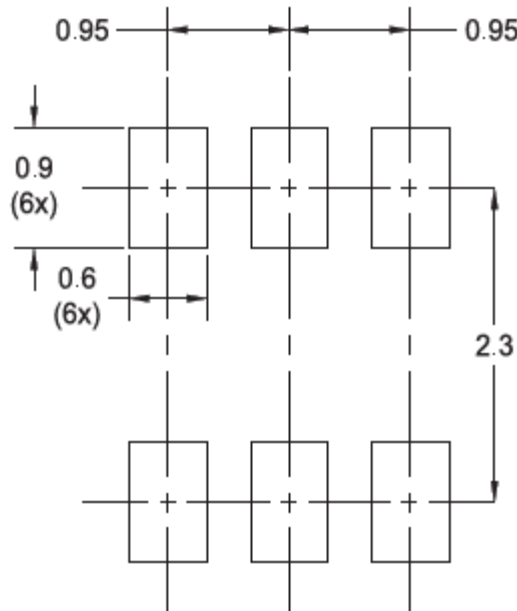

SOP8 Package Drawing

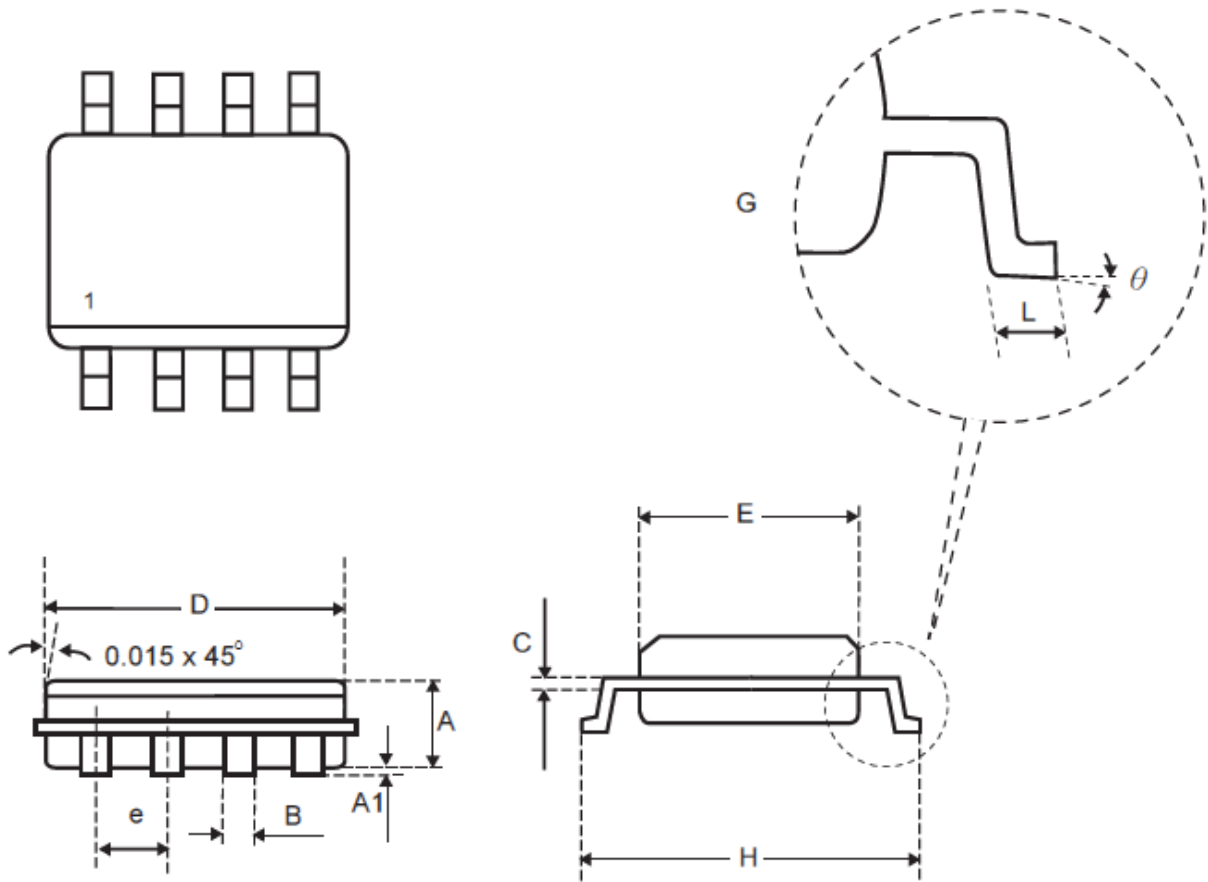

| SYMBOLS | MILLIMETERS | | INCHES | |
|---------|-------------|------|------------|-------|
| | Mjn. | Max. | Mjn. | Max. |
| A | 1.35 | 1.75 | 0.053 | 0.069 |
| A1 | 0.10 | 0.25 | 0.004 | 0.010 |
| B | 0.41 Typ. | | 0.016 Typ. | |
| C | 0.20 Typ. | | 0.008 Typ. | |
| D | 4.80 | 4.98 | 0.189 | 0.196 |
| E | 3.81 | 3.99 | 0.150 | 0.157 |
| e | 1.25 Typ. | | 0.05 Typ. | |
| H | 5.79 | 6.20 | 0.228 | 0.244 |
| L | 0.41 | 1.27 | 0.016 | 0.050 |
| θ | 0° | 8° | 0° | 8° |